

Symbolic Charge-Based MOSFET Model

C. Galup-Montoro and M. C. Schneider

Department of Electrical Engineering, Federal University of Santa Catarina
LCI/EEL/CTC/UFSC – 88040 900, Florianópolis, Brazil

carlos@eel.ufsc.br

marcio@eel.ufsc.br

ABSTRACT

This work aims at providing an accurate and complete symbolic model of the MOS transistor useful for the early stages of design. The main idea is to extend the simple formalism of drift transport to include both diffusion and velocity-limited transport. This new concept is supported by a charge-based model, in which we substitute a virtual charge for the inversion charge density. *The virtual charge is just the real inversion charge plus the pinch-off charge minus the saturation charge.* A direct consequence of the definition of the virtual charge is strong inversion-like representation of currents, charges as well as small-signal parameters.

Keywords: MOSFET, MOSFET model, charge-based model, symbolic model.

1 INTRODUCTION

The new generation of compact MOSFET models [1] provides accurate current, charge, capacitance and noise characteristics as numerical outputs of a rather complicated set of internal equations specific to each model. Numerical circuit simulation is a fundamental tool for circuit verification, but is not really useful in the early stages of design. Very simple models of the MOS transistor are customarily used at these stages, but they are not accurate, particularly for advanced technologies. This work aims at providing a new accurate and complete symbolic model of the MOS transistor useful for the early stages of design. The main idea behind this symbolic model is to preserve the simple formalism of strong inversion (SI) through a change of variable to render it capable of describing the actual transport including diffusion and saturation velocity effects. This new concept is supported by a charge-based model, in which we substitute a virtual charge for the inversion charge density. We will show that *the virtual charge is the real inversion charge plus the pinch-off charge (diffusion increases the current) minus the saturation charge (velocity saturation reduces the current).*

2 DRAIN CURRENT

The Pao-Sah expression for the drain current I_D , which includes the effects of both drift and diffusion, is

$$I_D = -\mu W Q'_I \frac{dV}{dy} \quad (1)$$

where μ is the mobility, W is the transistor width, Q'_I is the inversion charge density, and dV/dy is the gradient of the channel voltage (quasi-Fermi level splitting). Two fundamental expressions used in our derivations are the approximate linear relationship between inversion charge density and the surface potential ϕ_S for a given V_G

$$dQ'_I = nC'_{ox} d\phi_S \quad (2)$$

along with UCCM [3]

$$\frac{V_P - V}{\phi_t} = \frac{Q'_I}{Q'_{IP}} - 1 + \ln \left(\frac{Q'_I}{Q'_{IP}} \right) \quad (3)$$

where V_P is the pinch-off voltage, ϕ_t is the thermal voltage and $Q'_{IP} = -nC'_{ox}\phi_t$ is the pinch-off charge, which depends on the gate voltage and on technological parameters, and n is the slope factor. Using approximations (2) and (3) in (1) we find that

$$I_D = -\frac{\mu W}{nC'_{ox}} Q'_{It} \frac{dQ'_{It}}{dy} \quad (4)$$

$$Q'_{It} = Q'_I - nC'_{ox}\phi_t \quad (5)$$

Q'_{It} is the shifted (by the amount equal to $-nC'_{ox}\phi_t$) inversion charge density. Assuming the mobility to be constant along the channel, the integration of (4) between source ($y=0$) and drain ($y=L$) yields

$$I_D = \frac{\mu W}{C'_{ox}L} \frac{Q'^2_F - Q'^2_R}{2n} = I_{D0}(1 - \alpha^2), \quad (6)$$

where Q'_F and Q'_R are the values of Q'_{It} evaluated at source and drain, respectively.

$$Q'_{F(R)} = Q'_{IS(D)} - nC'_{ox}\phi_t \quad (7)$$

The (forward) saturation current I_{D0} and saturation coefficient α in (6) may be rewritten as

$$I_{D0} = \frac{\mu W Q_F'^2}{C_{ox}' L (2n)} \quad \text{and} \quad (8)$$

$$\alpha = \frac{Q_R'}{Q_F'} = \frac{Q_{ID}' - n C_{ox}' \phi_t}{Q_{IS}' - n C_{ox}' \phi_t} \quad (9)$$

The saturation coefficient α above is a generalization of the definition proposed in [2]. In effect, in SI and assuming zero bulk charge the relations given below hold.

$$\alpha \cong \frac{Q_{ID}'}{Q_{IS}'} \cong \frac{V_P - V_D}{V_P - V_S} \cong \frac{V_{GD} - V_{T0}}{V_{GS} - V_{T0}}. \quad (10)$$

Now, to calculate the effect of velocity saturation on the drain current, we follow the same procedure as that for the long-channel transistor. To obtain the new expression for the drain current we use the following approximation for the field-dependent mobility

$$\mu = \frac{\mu_0}{1 + \frac{\mu_0}{v_{lim}} \frac{d\phi_S}{dy}} = \frac{\mu_0}{1 + \frac{\mu_0}{v_{lim}} \frac{dQ_I'}{n C_{ox}' dy}}. \quad (11)$$

Taking into account approximations (2), (3), and (11), the Pao-Sah equation of the drain current becomes

$$I_D = -\frac{\mu_0 W}{n C_{ox}'} \frac{Q_I' - n C_{ox}' \phi_t}{1 + \frac{\mu_0}{v_{lim}} \frac{dQ_I'}{n C_{ox}' dy}} \frac{dQ_I'}{dy}. \quad (12)$$

Equation (12) can be rewritten as

$$dy = -\frac{\mu_0 W}{n C_{ox}' I_D} \left(Q_I' - n C_{ox}' \phi_t + \frac{I_D}{W v_{lim}} \right) dQ_I' \quad (13)$$

Expression (13) has very important properties. Firstly, because n depends only on V_G , and I_D is constant along the channel, we can define a virtual charge density that differs from the real charge along the channel by a constant term, i.e.,

$$Q_V' = Q_I' - n C_{ox}' \phi_t + \frac{I_D}{W v_{lim}} \quad (14)$$

The last two terms in (14), constant along the channel, have clear physical meanings: $-n C_{ox}' \phi_t$ is the pinch-off charge and $-I_D / W v_{lim}$ is the saturation charge, i.e., the minimum amount of carrier charge density required to

sustain a channel current equal to I_D . The virtual charge is the real inversion charge plus the pinch-off charge (diffusion increases the current) minus the saturation charge (velocity saturation reduces the current). From (14), the following equality holds along the transistor channel

$$dQ_V' = dQ_I'. \quad (15)$$

Now, inserting (14) and (15) into (13), we find that

$$dy = -\frac{\mu_0 W}{n C_{ox}' I_D} Q_V' dQ_V'. \quad (16)$$

Using the basic linear relationship between Q_I' and ϕ_S given by (2), equation (16) becomes equivalent to

$$I_D = -\mu_0 W Q_V' \frac{d\phi_S}{dy}, \quad (17)$$

which corresponds to the drift-only current of the virtual charge Q_V' . We can adopt the following definition for the virtual charge: *The drift of the virtual charge produces the same current as the actual movement of the real charge, which includes drift, diffusion and velocity saturation.* The use of the virtual charge allows us to extend the formalism of strong inversion to the general case of drift-diffusion plus velocity saturation. This result is similar to the one presented by Maher and Mead in [7].

The integration of (16) from source to drain results in

$$I_D = \frac{\mu_0 W}{C_{ox}' L} \frac{Q_{VS}'^2 - Q_{VD}'^2}{2n} = I_{D0} (1 - \alpha^2) \quad (18)$$

where, in this case the (forward) saturation current I_{D0} and saturation coefficient α in (18) become

$$I_{D0} = \frac{\mu W Q_{VS}'^2}{C_{ox}' L (2n)} \quad \text{and} \quad (19)$$

$$\alpha = \frac{Q_{VD}'}{Q_{VS}'} = \frac{Q_{ID}' - n C_{ox}' \phi_t + I_D / W v_{lim}}{Q_{IS}' - n C_{ox}' \phi_t + I_D / W v_{lim}} \quad (20)$$

Clearly, (18) is not useful as a stand-alone expression for calculating the current because Q_V' depends on the current itself. Nevertheless, the expression of the current in terms of the virtual charges at source and drain is instrumental for deriving simple expressions of stored charges and capacitive coefficients that keep the drift-only transport formalism. Just for the sake of completeness, the drain current can be calculated from the integration of (12) between source and drain, yielding

$$I_D = \frac{\mu_0 W}{2nC'_{ox}L} \frac{Q'_F{}^2 - Q'_R{}^2}{1 + \frac{\mu_0}{Lv_{lim}} \frac{Q'_R - Q'_F}{nC'_{ox}}}, \quad (21)$$

3 STORED CHARGES

The splitting of the inversion charge

$$Q_I = W \int_0^L Q'_I dy \quad (22)$$

into the source and drain charges according to

$$Q_S = W \int_0^L \left(1 - \frac{y}{L}\right) Q'_I dy \quad \text{and} \quad (23)$$

$$Q_D = W \int_0^L \frac{y}{L} Q'_I dy, \quad (24)$$

as presented in [4]. Such a partitioning of the inversion charge density, based on charge conservation, is valid for the quasi-static model, where the charge distribution in the channel is given by the dc distribution calculated considering the instantaneous values of the terminal voltages.

3.1 Long-channel transistor

In the following, we derive the charge expressions for long-channel transistors and then include short-channel effects. All the information necessary to calculate the stored charges in the quasi-static approximation is available in the dc current model of the transistor.

To derive the long-channel stored charges, we make $v_{lim} \rightarrow \infty$. Then, substituting (5) and (13) into (22) yields:

$$Q_I = -\frac{\mu_0 W^2}{I_D n C'_{ox}} \left[\int_{Q'_F}^{Q'_R} (Q'_I + n C'_{ox} \phi_t) Q'_I dQ'_I \right] \quad (25)$$

The integration of (25) gives

$$Q_I = -\frac{\mu_0 W^2}{nC'_{ox} I_D} \left[\frac{Q'_R{}^3 - Q'_F{}^3}{3} + n C'_{ox} \phi_t \frac{Q'_R{}^2 - Q'_F{}^2}{2} \right] \quad (26)$$

To find the source and drain charges we first find y in terms of the shifted charge through the integration of (13) from the source ($y=0$) to an arbitrary point y of the channel, which gives (for $v_{lim} \rightarrow \infty$)

$$y = \frac{\mu_0 W}{2nC'_{ox} I_D} (Q'_F{}^2 - Q'_I{}^2) \quad (27)$$

The expressions for the channel-related charges in terms of the source inversion charge density and the saturation

coefficient α , are summarized in Table 1 (for long-channel devices, $v_{lim} \rightarrow \infty$ and $\Delta L \rightarrow 0$). As seen in Fig. 1, in spite of their complicated aspect, the functions of the parameter α are well behaved, slightly varying functions in the physically meaningful interval $0 < \alpha \leq 1$. These functions give, for a non uniform channel ($0 < V_{DS}$, or $\alpha < 1$), average values of the inversion charge density in the channel

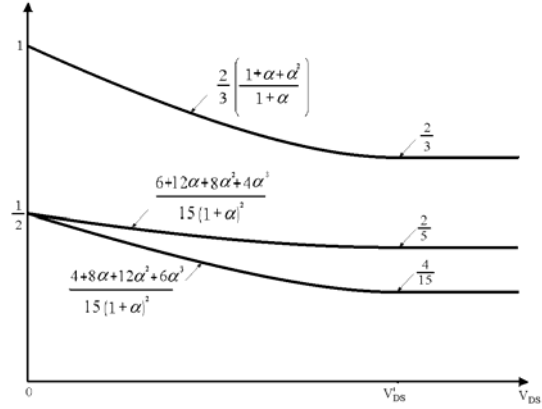

Fig. 1 Functions of the inversion coefficient α appearing in the channel charge expressions

An approximate expression for the depletion charge, linear in terms of the inversion charge can also be readily obtained, as demonstrated in [3]

$$Q_B = -\frac{n-1}{n} Q_I + Q'_{Ba} W L \quad (28)$$

Q'_{Ba} is the depletion charge density deep in weak inversion. The stored charges in terms of the gate voltage are shown in Fig. 2.

3.2 Short-channel transistor

To calculate the total inversion charge, the channel is split into the saturated and non-saturated regions. In the saturated region the inversion charge density is assumed to be constant; therefore, the inversion charge is given by

$$Q_I = W \int_0^{L-\Delta L} Q'_I dy + W \Delta L Q'_{IDsat} \quad (29)$$

where $Q'_{IDsat} = -I_D / W v_{lim}$ is the minimum amount of carrier charge density to sustain a channel current equal to I_D and ΔL is the channel-length shortening. To determine the inversion charge in (29) we calculate Q'_I in terms of Q'_V by means of (14) and y in terms of Q'_V using (16), which yields the total inversion charge presented in

Table 1. The source and drain charges can be determined in a similar way, resulting in the values given in Table 1.

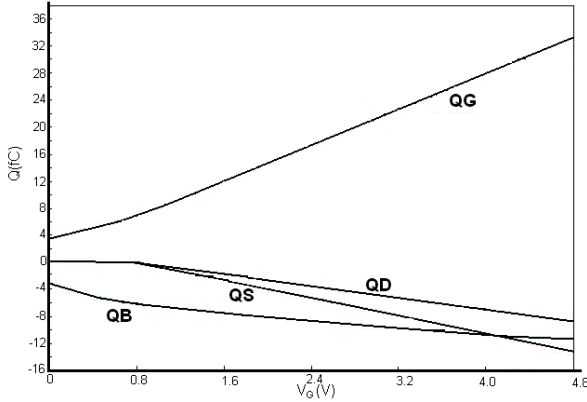

Fig. 2 The charges at the gate (Q_G), source (Q_S), drain (Q_D) and bulk (Q_B) terminals versus V_G for an NMOS transistor with $W/L=10\mu\text{m}/0.8\mu\text{m}$. ($V_D=2\text{V}$, $V_S=0\text{V}$)

The effect of velocity saturation is an increase in the absolute values of the total inversion charges in saturation as a consequence of the non zero charge density at the drain end. This effect is illustrated in Fig. 3 where the source and drain charges considering velocity saturation are plotted together with the charges obtained from the long channel model.

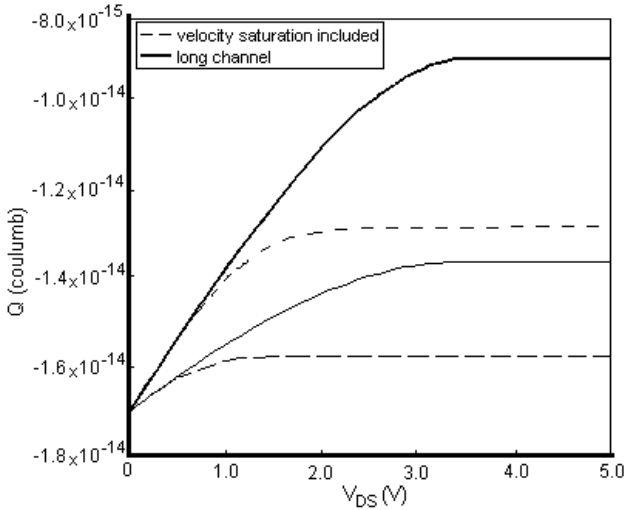

Fig. 3 Source and drain charges versus drain voltage for long-channel device and for short-channel device [6]

4 CAPACITIVE COEFFICIENTS

The four-by-four matrix of the MOSFET intrinsic capacitances for quasi-static operation is defined according to

$$\begin{pmatrix} dQ_G/dt \\ dQ_S/dt \\ dQ_D/dt \\ dQ_B/dt \end{pmatrix} = \begin{pmatrix} C_{gg} & -C_{gs} & -C_{gd} & -C_{gb} \\ -C_{sg} & C_{ss} & -C_{sd} & -C_{sb} \\ -C_{dg} & -C_{ds} & C_{dd} & -C_{db} \\ -C_{bg} & -C_{bs} & -C_{bd} & C_{bb} \end{pmatrix} \begin{pmatrix} dV_G/dt \\ dV_S/dt \\ dV_D/dt \\ dV_B/dt \end{pmatrix} \quad (30)$$

Only nine out of the sixteen capacitive coefficients in (30) are linearly independent, due to charge conservation and charge transfer dependence on voltage differences only [Tsvividis 99].

An appropriate set (among many) of capacitive coefficients is represented by equations (31) and (32). The circuit equivalent to equations (31) is presented in Fig. 4.

$$\begin{aligned} \frac{dQ_G}{dt} &= C_{gs} \frac{dV_{GS}}{dt} + C_{gd} \frac{dV_{GD}}{dt} + C_{gb} \frac{dV_{GB}}{dt} \\ \frac{dQ_B}{dt} &= C_{gb} \frac{dV_{BG}}{dt} + C_{mx} \frac{dV_{BG}}{dt} + C_{bs} \frac{dV_{BS}}{dt} \\ &\quad + C_{bd} \frac{dV_{BD}}{dt} \end{aligned} \quad (31)$$

$$\begin{aligned} \frac{dQ_D}{dt} &= C_{gd} \frac{dV_{DG}}{dt} + C_{bd} \frac{dV_{DB}}{dt} - C_m \frac{dV_{GB}}{dt} \\ &\quad + C_{sd} \frac{dV_{DB}}{dt} - C_{ds} \frac{dV_{SB}}{dt} \end{aligned}$$

where

$$\begin{aligned} C_m &= C_{dg} - C_{gd} \\ C_{mx} &= C_{bg} - C_{gb} \end{aligned} \quad (32)$$

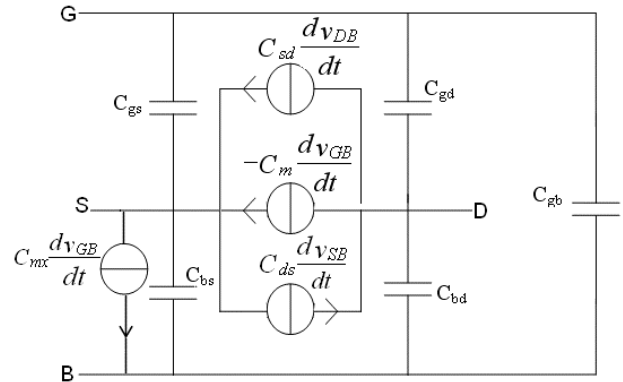

Fig. 4 Quasi-static small-signal model for the charging currents of the MOS transistor

The determination of the capacitive coefficients in (30) requires calculating the derivatives of charges wrt voltages.

Let us first write the charge balance equation.

$$Q_G = -(Q_I + Q_B + Q_{OX}) = -\frac{Q_I}{n} - Q'_{Ba} WL - Q_{OX} \quad (33)$$

Capacitances C_{gs} and C_{gd} can be obtained deriving the gate charge in (33) wrt $V_{S(D)}$, yielding

$$C_{gs(d)} = -\frac{\partial Q_G}{\partial V_{S(D)}} = \frac{1}{n} \frac{\partial Q_I}{\partial V_{S(D)}} \quad (34)$$

The remaining capacitances can be calculated in a similar fashion. The results for the capacitive coefficients are given in Table 2.

Some comments about the capacitive model of the MOSFET are timely: (i) when the variation of n with V_G is assumed to be negligible, then $C_{gb} = C_{bg}$ and the simplified set of eight capacitive coefficients in Table 2 results; (ii) g_{ms} , g_{md} , and g_{mg} are the source, drain, and gate transconductances, respectively; (iii) The use of the generalized saturation coefficient α allows a very compact formulation of the capacitive coefficients.

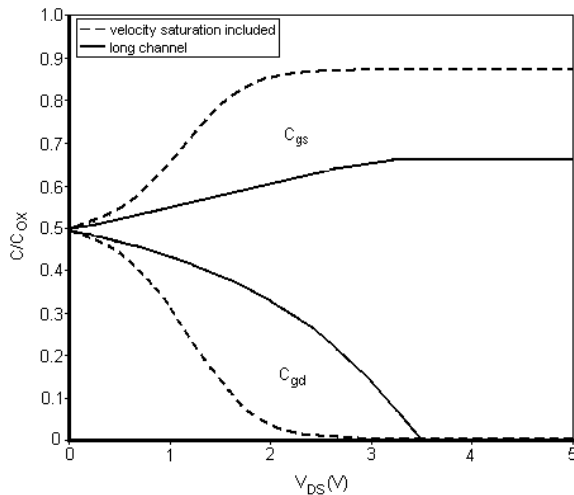

Fig. 5. Normalized gate-to-source and gate-to-drain capacitances versus drain voltage

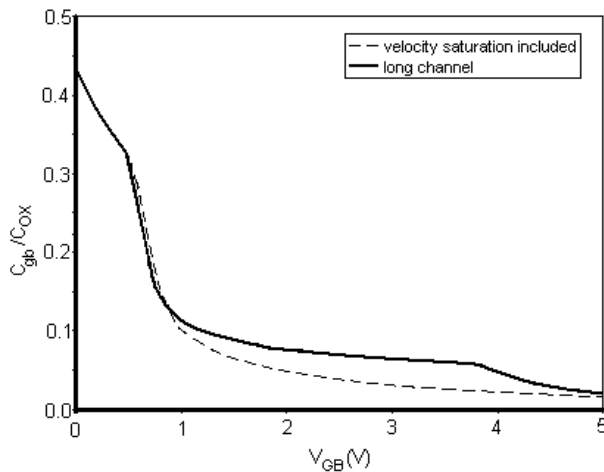

Fig. 6 Gate-to-bulk capacitance with and without the effect of velocity saturation [6]

Fig. 5 shows C_{gs} and C_{gd} , normalized to the gate capacitance C_{ox} , versus V_D , calculated according to the expressions of Table 2. These capacitances saturate for lower V_{DS} values when we include velocity saturation, which is consistent with the reduced value of V_{DSsat} obtained when velocity saturation is considered. The plots of other capacitive coefficients are shown in Figs. 6 and 7. In all cases the effect of velocity saturation is to make capacitances vary more gradually as compared to the long-channel case.

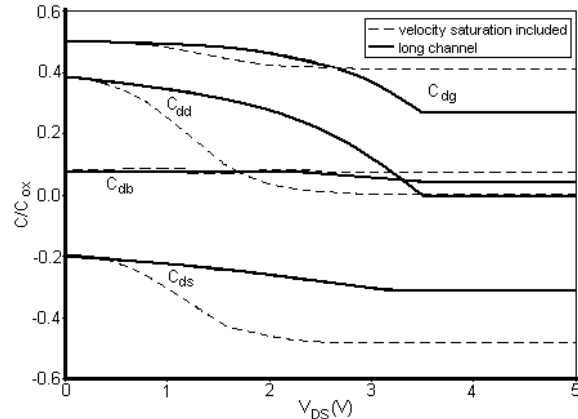

Fig. 7 Drain charge related capacitances calculated with (...) and without (____) carrier velocity saturation [6].

ACKNOWLEDGMENTS

The authors wish to thank CNPq for the partial financial support of this work.

5 REFERENCES

- [1] J. Watts et al., "Advanced compact models for MOSFETs," Proc. WCM, Nanotechnology Conf. and Trade Show, Anaheim, CA, pp. 3-12, 2005.
- [2] J. J. Paulos, and D. A. Antoniadis, "Limitations of quasi-static capacitance models for the MOS transistor", IEEE EDL, vol. 4, no. 7, pp. 221-224, 1983.
- [3] C. Galup-Montoro, M. C. Schneider, and A. I. A. Cunha (1999), "A current-based MOSFET model for integrated circuit design," Chapter 2 of *Low-Voltage/Low-Power Integrated Circuits and Systems*, pp 7-55, edited by E. Sánchez-Sinencio and A. Andreou, IEEE Press.
- [4] S-Y. Oh, D. E. Ward, and R. W. Dutton, "Transient analysis of MOS transistors," IEEE TED, vol. 27, no. 8, pp. 1571-1578.
- [5] Y. Tsvetkov, *Operation and Modeling of the MOS Transistor*, WCB/McGraw-Hill, 2nd ed, 1999.
- [6] O. C. Gouveia Filho, *Um modelo compacto do transistor MOS para simulação de circuitos*, Ph.D. thesis, Universidade Federal de Santa Catarina (in Portuguese), 1999.
- [7] M. A. Maher and C. A. Mead, "A physical charge-controlled model for MOS transistors," in

Table 1 Total inversion, source and drain charges as a function of the inversion charge density at source and the saturation coefficient α

$Q_I = W(L - \Delta L) \left[\frac{2}{3} \frac{1 + \alpha + \alpha^2}{1 + \alpha} Q'_{VS} + nC'_{ox}\phi_t \right] - \frac{LI_D}{v_{lim}} \quad (35)$
$Q_S = \frac{W(L - \Delta L)^2}{L} \left[\frac{6 + 12\alpha + 8\alpha^2 + 4\alpha^3}{15(1 + \alpha)^2} Q'_{VS} + \frac{n}{2} C'_{ox}\phi_t \right] - \frac{LI_D}{2v_{lim}} \quad (36)$
$Q_D = \frac{W(L - \Delta L)^2}{L} \left(\frac{4 + 8\alpha + 12\alpha^2 + 6\alpha^3}{15(1 + \alpha)^2} Q'_{VS} + \frac{nC'_{ox}\phi_t}{2} \right) - \frac{LI_D}{2v_{lim}} \quad (37)$

Table 2 Intrinsic (trans)capacitances

Variable	Expression
C_{gs}	$\frac{2}{3} W L_e C'_{ox} \frac{1 + 2\alpha}{(1 + \alpha)^2} \frac{q'_{IS}}{1 + q'_{IS}} + \frac{L_e g_{ms} (1 - \alpha)^2}{3 n v_{lim} (1 + \alpha)^2}$
C_{gd}	$\frac{2}{3} W L_e C'_{ox} \frac{\alpha^2 + 2\alpha}{(1 + \alpha)^2} \frac{q'_{ID}}{1 + q'_{ID}} - \frac{L_e g_{md} (1 - \alpha)^2}{3 n v_{lim} (1 + \alpha)^2}$
$C_{bs(d)}$	$(n - 1) C_{gs(d)}$
$C_{gb} = C_{bg}$ (*)	$\frac{n - 1}{n} \left(C_{ox} - C_{gso} - C_{gdo} - \frac{L_e g_{mg} (1 - \alpha)^2}{3 v_{lim} (1 + \alpha)^2} \right)$
C_{ds}	$-\frac{4}{15} n C'_{ox} W \frac{L_e^2}{L} \frac{1 + 3\alpha + \alpha^2}{(1 + \alpha)^3} \frac{q'_{IS}}{1 + q'_{IS}} - \frac{1}{30} \frac{g_{ms} L_e^2 (3\alpha + 7)(1 - \alpha)^2}{v_{lim} L (1 + \alpha)^3}$
C_{sd}	$-\frac{4}{15} n C'_{ox} W \frac{L_e^2}{L} \frac{\alpha + 3\alpha^2 + \alpha^3}{(1 + \alpha)^3} \frac{q'_{ID}}{1 + q'_{ID}} + \frac{1}{30} \frac{g_{md} L_e^2 (3 + 7\alpha)(1 - \alpha)}{v_{lim} L (1 + \alpha)^3}$
α	$\frac{Q'_{VD}}{Q'_{VS}} = \frac{Q'_{ID} - n C'_{ox}\phi_t + \frac{I_D}{W v_{lim}}}{Q'_{IS} - n C'_{ox}\phi_t + \frac{I_D}{W v_{lim}}}$
	$L_e = L - \Delta L \quad q'_{IS(D)} = \frac{Q'_{IS(D)}}{-n C'_{ox}\phi_t}$

(*) C_{gso} and C_{gdo} are the first terms in C_{gs} and C_{gd} , respectively